

B22

köster



The Task

- The market demands widely customizable double-head counting machine in different configurations.
- The focus is on easy adaptation of the versions to the customer's processes and needs.

The Solution

- Our new Köster HPC B22 universal double head counting machine.
- Widely customizable.
- Compatible with all counting discs from our range.

The Advantages

- High-efficiency - Simple operation
- High-accuracy - 99%
- High-flexibility - Range from 35 - 500 g/m²
- High-durability - Solid, high-quality construction
- High-cost effectiveness - Low maintenance costs

The Substrates

- Cellulose-based products
- Cotton-based products
- Cardboard-based products
- Polymer-based products
- Coated products
- Hybrid products
- Laminated products
- And much more

B22

The Counting Head

- Köster air suspension instead of the conventional mechanical weight compensation.
- Quick and easy adjustment of the weight of the counting head, the vacuum power and the pressing force of the press plates via independent pressure regulators.

The Standard Machine

- Left counting head:
 - Fixed.
 - Corner counting position.
- Right counting head:
 - Movable.
 - Electrically adjustable to format size.
 - Laser sensor-controlled positioning check in case the sheet length is exceeded.
- Large and strong alignment stops at the counting heads.
- Additional alignment stops between and next to the counting heads can be mounted.
- Ready to use C “corner counting” or S “edge counting” discs:
 - Heads can be independently equipped with “C” or “S” discs.
- Airflow machine table:
 - Hard anodized aluminium.
 - Microperforated.
- Plug & Play commissioning.
- To the machine frame integrated printer location.
- Standard voltage supply Single-phase 230V-AC / 50-60Hz.

The Operation

- Counting direction from top to bottom.
- Best ergonomics for the operator.
- Large working height adjustment range 790 – 1100 mm.
- Precise and fast product handling.
- No adapters required.
- Solid alignment stops at the counting heads.
- User-friendly HMI interface with single-sided user interface.

The Machine Design

- All installed components are high-quality products from global manufacturers.
- The machine design ensures easy maintenance and low upkeep costs as well as maximum machine availability.
- Machine's high performance and availability results from the robust and precise construction out of steel and aluminium.

The Options

- Tab inserter.
- Min. format length 210 mm without tab inserter.
- Min. format length 250 mm with left-sided tab inserter.
- Retractable lateral alignment rods.
- Lateral stamping unit.
- Integrated compressor.
- Casters.
- Printer kit.
- Warranty extension 24 months except wear parts.

The Functions

- Counting:
The layer is completely counted.
- Comparing:
Results are compared with the pre-set number, if they do not match,
a visual alarm is displayed.
- Batching:
A pre-set number can be easily batched to obtain a ream.
The counting disc is used for separation to provide a gap for the operator to easily separate the reams.
- Security Counting:
Results are compared with the pre-set number, if they do not match,
the product is not automatically released.
- Difference counting:
A pre-set number is compared with the amount in the layer.
Under or over quantities can be removed or added in the ream according to guided instructions to obtain the required quantity.
The counting disk is used for separation to provide the operator with a gap for easy removal of the excess quantity.

The Double Head Versions

B22

Standard Version

- Left counting head fixed, right counting head movable.
- Movable counting head is motor-driven to the desired position according to the programme settings.



The Double Head Versions

B22 RMH1

With Handwheel

- Left counting head fixed, right counting head movable.
- Movable counting head is driven manually by a handwheel.
- Mechanical millimetre display on the handwheel.

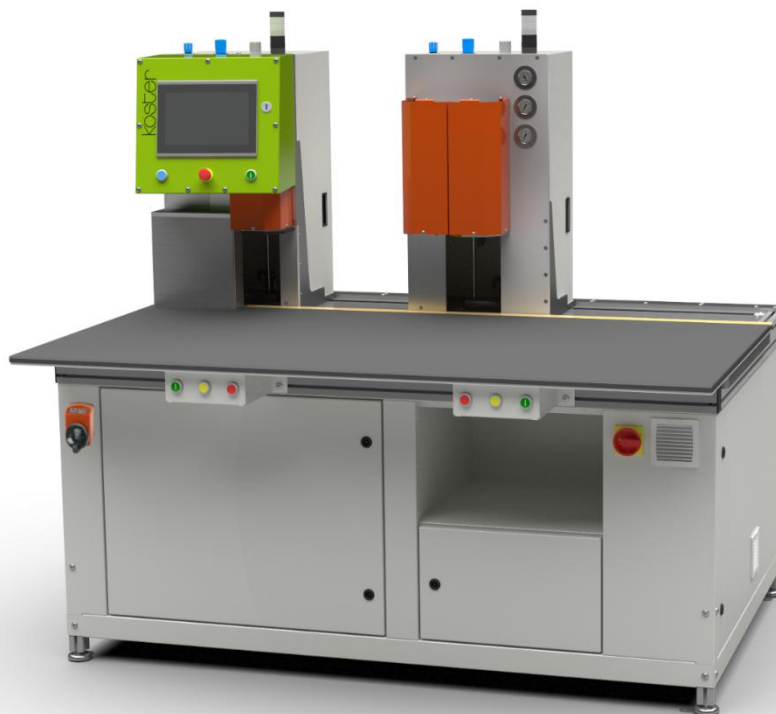

The Double Head Versions

B22 RMH2

With Two Mobile Heads

- Left counting head movable, right counting head movable.
- Both counting heads are motor-driven to the desired positions according to the programme settings.

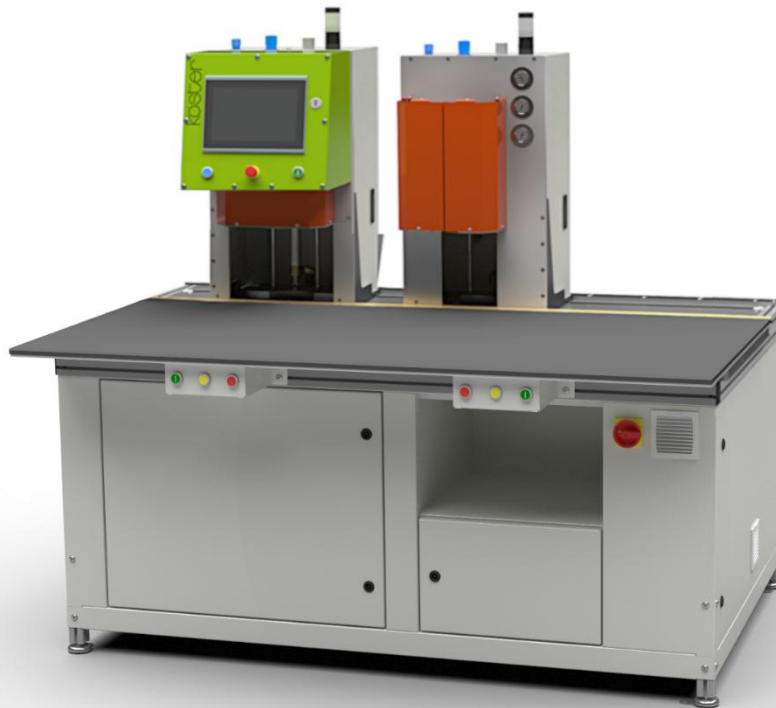

The Single Head Versions

B22 -10

Standard Version

- One left-hand counting head.
- Counting head fixed, not movable.



The Single Head Versions

B22 -10M

Edge Version

- One centred counting head.
- Counting head fixed, not movable.



The Unique Characteristics

B22

- Köster air suspension instead of the conventional mechanical weight compensation.
- Quick and easy adjustment of the weight of the counting head, the vacuum power and the pressing force of the press plates via independent pressure regulators.
- Highest maximum counting speed available on the market as standard:
 - 2000 RPM / min. (6 segments discs = 12.000 sheets / min.).
 - Compatible with 3,4 and 6 segments discs.
- The widest GSM range on the market: 35 g/m² - 500 g/m²
 - Discs available for a wide range of substrates.
- State-of-the-art drives:
 - Speed-independent torque availability.
 - No jamming of the disc at low revolutions.
 - Precise stopping.
 - Eliminates the risk of overcounting when the preset value is met.
- Depending on the substrate, the counting heads can be equipped with S-discs in parallel:
 - Edge and corner counting position with one disc type.
- Encapsulated counting heads:
 - User-friendly reduction of noise pollution.
 - The press-plates are integrated into the counting heads shells.
- Fully integrated User Access Management:
 - User access according to different user levels.
- Unrivaled precision:
 - Mono block steel base to assure machine rigidity.
- Space in the machine frame for installing a printer.

Technical Specifications

B22

Dimensions	L	W	H			
Overall (mm):	1680	1270	1644 - 1931			
Table (mm):	1680	900				
Working height (mm):	790 - 1100					
Machine weight (kg):	400 - 500					
Supplies						
Electric:	Single-phase 230V-AC / 50-60Hz / max. back-up fuse 16A / full load current 15A					
Pneumatic:	Min. 6 bar / oil and water-free / consumption 400 l/h					
Layer height						
Min. (mm):	10					
Max. (mm):	200					
	Standard		1-tab inserter		2-tab inserters	
Corner Counting	L	W	L	W	L	W
Min. format size (mm):	295	80	295	80	295	80
Max. format size (mm):	1090	900	1090	900	1090	900
	Standard		1-tab inserter		2-tab inserters	
Edge Counting	L	W	L	W	L	W
Min. format size (mm):*	295	80	300	80	350	80
Max. format size (mm):	1680	900	1680	900	1680	900
*Depending on the product to be processed.						

The Unique Characteristics

B22

Adjustment of the weight of the counting head, the vacuum power and the pressing force of the press plates via pressure regulators.

Encapsulated counting head to reduce noise during counting.

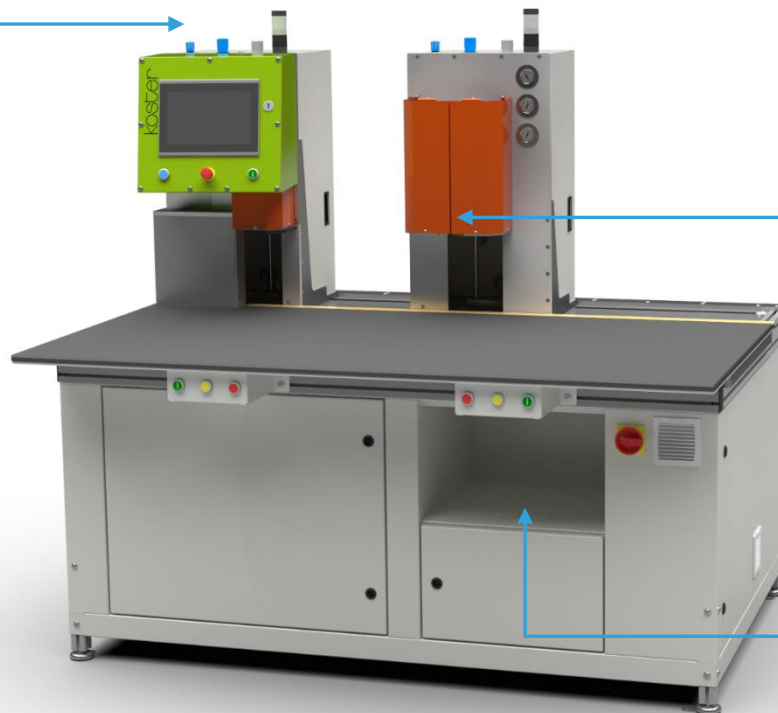

Space in the machine frame for installing a printer.

Machine Layout

B22

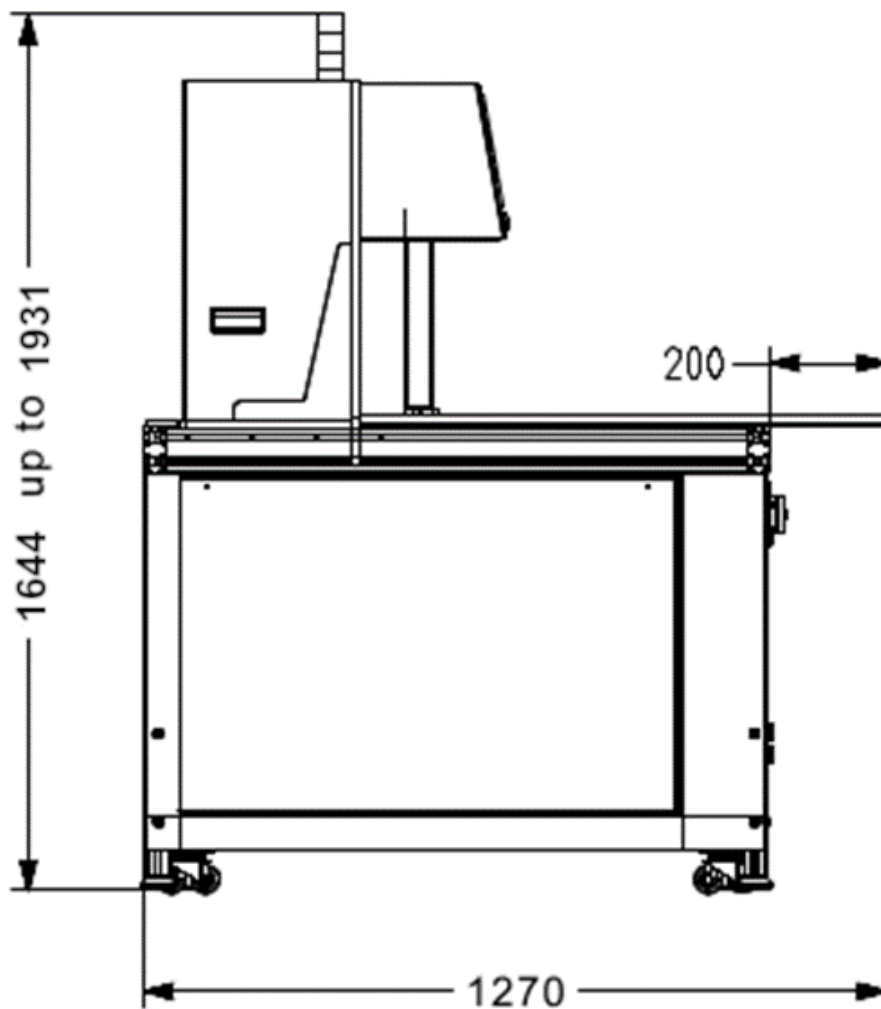

Technical Specifications

B22

Counting Technology	Disc				
Counting Direction:	Top to Bottom				
Counting Speed	Max. RPM	Type	Segments	Sheets/Min.	Sheets/Sec.
Rated RPM:	2.000	C,S	3	6.000	100
Rated RPM:	2.000	C,S	4	8.000	133
Rated RPM:	2.000	C,S	5	10.000	166
Rated RPM:	2.000	C,S	6	12.000	200
Depending on the rigidity and quality of the products, these values may vary during processing.					
Processable Substrates					
Currency Industry:	Currency and documents paper, coated or uncoated, polymers, hybrids and much more.				
Consumer Industry:	Consumer paper, coated or uncoated, laminated, plastics, polymers, paperboards, cardboards and much more.				
PLC Control					
Brand:	B&R				
Touchscreen:	10,1" coloured multilingual, main HMI with pictograms				
Interfaces:	FTP (Client / Server)/USB/Profinet/Profibus/Ethernet-IP/EtherCat...				
Operating Noise					
Max. dB(A) at 2000 RPM.:	78				
Environmental conditions	Min.		Max.		
Recommended temperature range (+°C):	15		35		
Recommended relative humidity range (%):	35		45		
Certification	CE declaration, in accordance with all applicable European standards.				

Machine Layout

B22

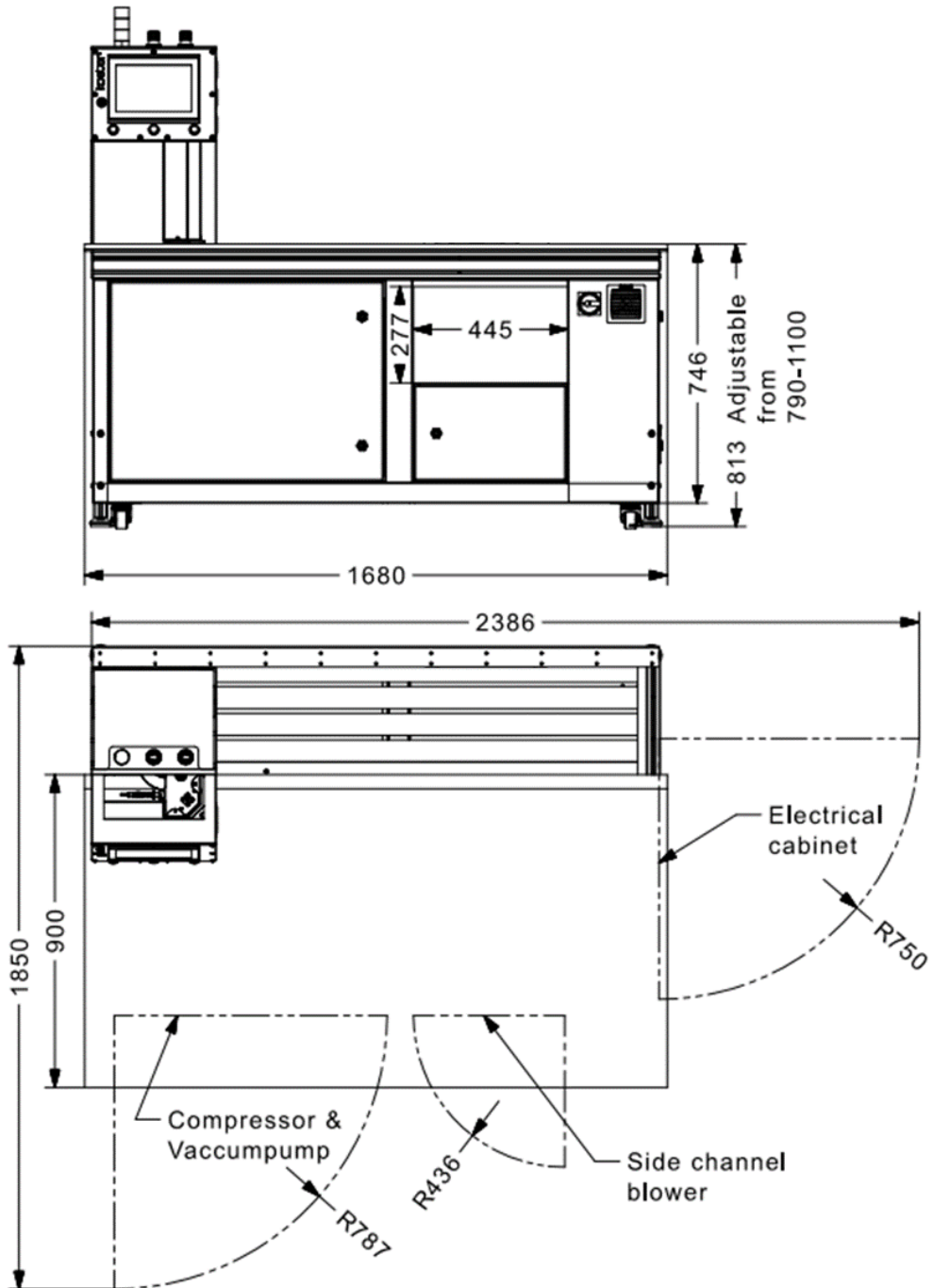

Basic Information

Discs

- The details of the GSM values are based on experience and tests. Depending on the product rigidity, these values may differ.
- Older produced counting discs for corner position are designated by 1xx,x for the diameter in "mm" and / or "V8 - V15" depending on the type.
- Newly produced counting discs for corner position are designated by "C1-Cx" depending on the type.
- Newly produced counting discs for edge position are designated by "S1-Sx" depending on the type.
- Warranty for the lifetime of the counting discs is not granted as the abrasive wear depends highly to the processed product.

Machines

- Maximum counting speed refers generally to the rated maximum rpm value and the machine design.
- It is not granted that maximum speed can be attended using all kind of substrates / materials.
- Warranty time 12 months upon issuing of the acceptance certificate.
- Warranty extension of 24 months optionally available.
- Warranty coverage except wear parts.

HPC – HIGH PERFORMANCE COUNTING



köster

Köster GmbH · Robert-Bosch-Straße 4 · D-74182 Obersulm-Willsbach
Telefon: +49(0)71344051 · E-Mail: service@koester-gmbh.de · Internet: www.koester-gmbh.de